

LEADING THE WAY OF INNOVATION

H4 PLUS Wafer Handling Robots

Diamond Series



The Diamond H4 Plus series Dual-Arm atmospheric robots represent a significant engineering advancement in the design and reliability of wafer handling equipment.

Two independent arms (R1 and R2) attached to a common rotary axis (T) allow fast swapping or simultaneous transfer of two wafers. The integrated linear (K) axis within the robot's body enables extended reach and efficient wafer handling.

Benefiting from technologically superior components, the robots utilize ultra low inertia, high-response brushless servomotors coupled with zero-backlash Harmonic Drive® gears to achieve greatly enhanced dexterity and precision.

The innovative, all-in-one, class 1 clean room compatible design incorporates the motion controller, servo amplifiers, and power supply within the robot's industry standard footprint.

A 32-bit, real-time kernel delivers accurate motion profiling along smooth continuous trajectories, while the distributed control architecture allows a seamless integration with linear tracks, pre-aligners, and other sub-components.

Networkable RS-485 and Ethernet interfaces complement the standard RS-232 and teach pendant connections. Powerful native wafer handling and scripting languages facilitate rapid software development for embedding the robots into an OEM application environment.

- Payload
up to 2.2 lbs (1 kg) per arm
- Encoders
Absolute, 131072 pulse/rev
- Motor type
Brushless,
low inertia high response
- Weight
120 lbs (55 kg)
- Cleanliness
Class 1 clean room
environment compatible
- Operating temperatures
50°F-104°F (10°C to 40°C)
- Facility requirements
Voltage range
100-120AVC, 200-240VAC
Vacuum supply
11.8" Hg (-5.8psi) /
0.1CFM airflow

FEATURES

- *Excellent structural rigidity*
- *Modular and highly customizable design*
- *Arm length 13.70"*
- *Vertical travel 13"*
- *Fully integrated motion controller, servo amplifiers and power supply*
- *High response brushless motors and precise zero-backlash Harmonic Drive® gears*
- *Absolute encoders eliminating the initial homing procedure*
- *Handling radial and in-line equipment placement*
- *Seamless integration with prealigner, linear track and other peripheral components*
- *Standard RS-232 interface and Ethernet (Telnet) interfaces to the host computer*
- *Advance 32-bit real-time motion control kernel*
- *Powerful wafer handling firmware*
- *Comprehensive software tools and utilities*
- *Software emulation for legacy robot macro commands*
- *General purpose digital inputs and outputs for custom use*
- *Class 1 clean-room environment compatibility*
- *Reliability - MTBF > 60,000 hours (MCFB > 10,000,000 cycles)*

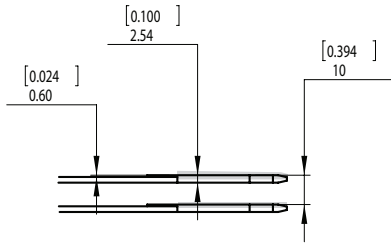
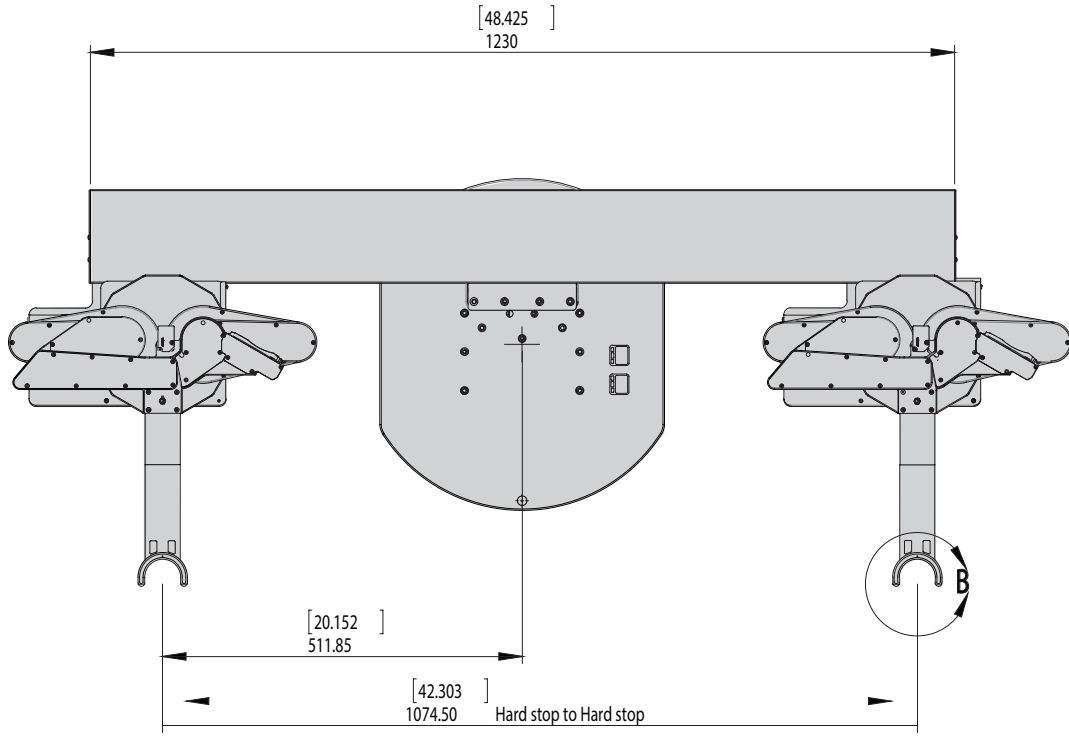

DETAIL D

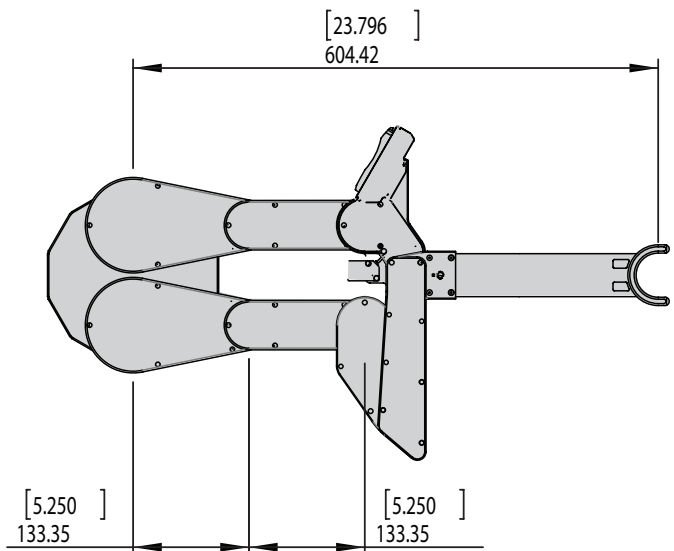
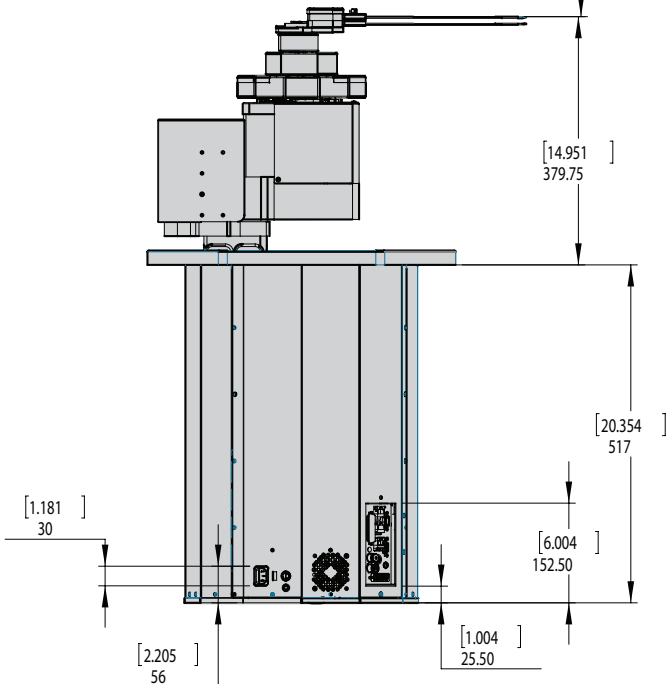
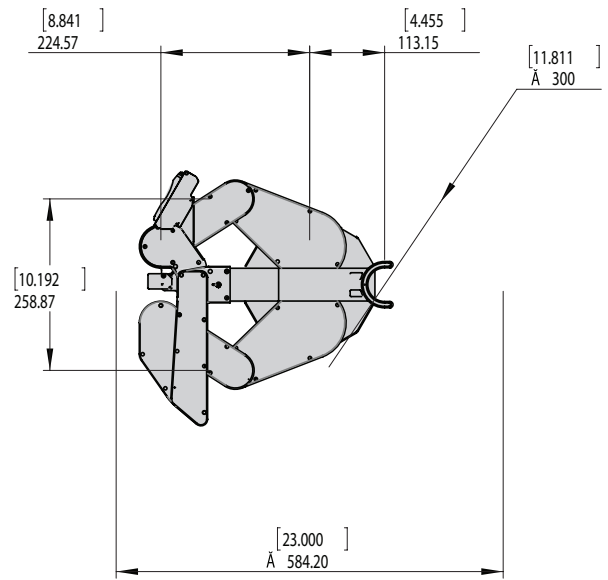
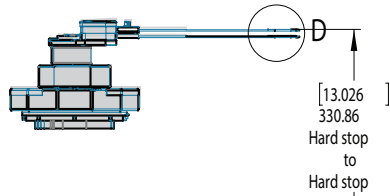

Axis	Motion	Maximum velocity	Maximum acceleration	Axis Repeatability
T	> 360°	400°/s	1500°/s ²	±0.01°
R1, R2	±13.6"	50 inch/s	300 inch/s ²	±0.001" (0.025mm)
Z	13"	18 inch/s	44 inch/s ²	±0.001" (0.025mm)
K	40"	50 inch/s	100 inch/s ²	±0.001" (0.025mm)



End Effector Mounting Interface

10.5" arms

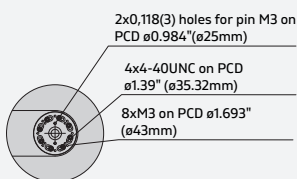

13.7" and 17" arms

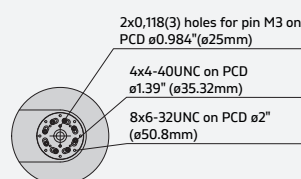

20" arms

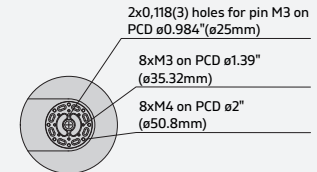

Made in USA by Milara®, Inc. (www.milarasmt.com), Designed by Logosol, Inc. (www.logosolinc.com)



49 Maple Str., Milford, MA 01757, USA



+1.508.533.5322



sales@milarasmt.com